

FLOATING MOUNT ROTOR ORDER FORM

PO #: _____ Date: _____

BILLING ADDRESS:

Name: _____

Address: _____

City: _____ State: _____

Zip: _____ Country: _____

Daytime Phone: _____

SHIPPING ADDRESS:

Name: _____

Address: _____

City: _____ State: _____

Zip: _____ Country: _____

Daytime Phone: _____

SHIP VIA: UPS Ground UPS 3rd Day UPS 2nd Day UPS Overnight

Other: _____

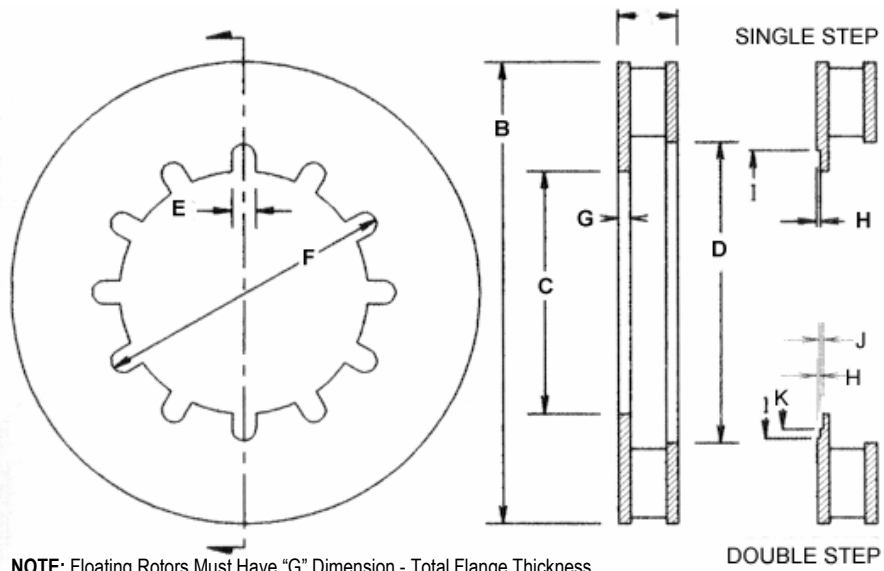

NOTE: Floating Rotors Must Have "G" Dimension - Total Flange Thickness

A - THICKNESS	
B - OUTSIDE DIAMETER	
C - FLANGE DIAMETER	
D - EYE DIAMETER	
E - SLOT WIDTH	
F - SLOT TIP TO TIP	
G - FLANGE THICKNESS	
H - STEP DEPTH	
I - STEP DIAMETER	
J - STEP DEPTH	
K - STEP DIAMETER	
L - NUMBER OF SLOTS	

FLOATING MOUNT ROTOR OPTIONS	<input type="checkbox"/> GAS VENTS (Cross Drilling May Cause Premature Rotor Cracking and Excessive Pad Wear) NUMBER OF SLOTS PER SIDE <input type="text"/>
	<input type="checkbox"/> CROSS DRILLED (Cross Drilling May Cause Premature Rotor Cracking and Excessive Pad Wear)
	<input type="checkbox"/> HEAT TREATING (Stress Relieves and Shortens Break In Period)
	<input type="checkbox"/> BALANCING (Most Racing Applications Do Not Require Balancing)
	<input type="checkbox"/> T-LOCK BLOCKS _____ NUMBER OF T-LOCKS DESIRED <input type="text"/>

METHOD OF PAYMENT: COD (\$7.00 charge) VISA Master Card Account

OTHER: _____

Card Number: _____

Exp. Date: _____

Name as appears on card

Signature